

## High Pressure Checkball Piston Pumps

Fixed displacement checkball pumps, with bi-directional shaft rotation, provide constant direction of output flow regardless of the direction of drive shaft rotation.

### OPERATING ADVANTAGES

Inlet and outlet check valves in each piston pumping chamber give checkball design pumps unique advantages. The positive seating action provides greater volumetric efficiency, especially at higher pressures.

The check valves take the place of a valveplate used in other pump designs. With no metal-to-metal rotating surface, checkball pumps are resistant to wearing and scoring, providing longer life with lower lubricity and contaminated fluids.

### TYPICAL APPLICATIONS

Reduced power requirements, as low as 1.0 HP at 10 000 psi (0,75 kW at 700 bar) @ 1500 rpm, make these pumps ideal for use in remote locations with limited power supply.

These compact pumps can be used on portable power packs for high-pressure torque wrenches and other service tools.

### PUMP SELECTION

The table shows specifications for standard pressure models and "H" option models for use at pressures higher than 8000 psi (560 bar).

Ordering a PF500 Series pump requires a complete model code specifying drive shaft, seal, and outlet port options.

Refer to *Typical Model Code* on page 6.

### Maximum Pressure

The max pressures listed in the table are the pressures a pump can sustain for occasional, short periods of operation without appreciably reducing life expectancy.

### PF500 SERIES

**0.16 to 0.68 gpm (0,59 to 2,58 L/min) at 1800 rpm**  
**Rated: 10 000 psi (700 bar), Maximum: 15 000 psi (1040 bar)**



### Specifications

Pump Models	Output Flow at 1500 rpm <sup>①</sup>		Output Flow at 1800 rpm <sup>①</sup>		Rated Pressure		Max. Pressure		Rated Speed	Max. Speed
	U.S. gpm	L/min	U.S. gpm	L/min	psi	bar	psi	bar	rpm <sup>②</sup>	rpm <sup>③</sup>
PF501-20	0.13	0,49	0.16	0,61	8000	560	8000	560	1800	3600
PF504-20	0.21	0,79	0.25	0,95	8000	560	8000	560	1800	3600
PF507-20	0.29	1,10	0.35	1,32	8000	560	8000	560	1800	3600
PF510-20	0.42	1,59	0.51	1,93	8000	560	8000	560	1800	3600
PF511-20	0.17	0,64	0.21	0,79	8000	560	8000	560	1800	3600
PF514-20	0.27	1,02	0.33	1,25	8000	560	8000	560	1800	3600
PF517-20	0.38	1,44	0.46	1,74	8000	560	8000	560	1800	3600
PF520-20	0.56	2,12	0.68	2,57	8000	560	8000	560	1800	3600
PF501H-20	0.12	0,45	0.15	0,57	10 000	700	15 000	1040	1800	3600
PF504H-20	0.20	0,76	0.24	0,91	10 000	700	15 000	1040	1800	3600
PF507H-20	0.27	1,02	0.33	1,25	10 000	700	15 000	1040	1800	3600
PF510H-20	0.42	1,59	0.50	1,89	10 000	700	15 000	1040	1800	3600
PF511H-20	0.16	0,61	0.19	0,72	10 000	700	15 000	1040	1800	3600
PF514H-20	0.27	1,02	0.32	1,21	10 000	700	15 000	1040	1800	3600
PF517H-20	0.37	1,40	0.45	1,70	10 000	700	15 000	1040	1800	3600
PF520H-20	0.55	2,08	0.66	2,50	10 000	700	15 000	1040	1800	3600

① Output flow based on typical performance at rated pressure with pressurized inlet where required, as shown in the table on page 2.

② Contact the Dynex Sales department for applications requiring continuous duty operation at speeds higher than 1800 rpm or lower than 900 rpm. See "Typical Performance Curves" on page 5.

③ Higher than rated speeds may require a pressurized inlet. Refer to "Inlet Conditions" on page 2.

## INSTALLATION AND OPERATION

Refer to *Checkball Pumps Service, Installation and Operating Instructions* for general installation and operating recommendations.

Consult the Sales department for applications that require operating above rated pressures, or at continuous duty above or below speeds shown in the *Typical Performance Curves* on page 5.

### Mounting

SAE A-A 2-bolt pattern with 0.25 inch (6,4 mm) pilot engagement.

### Shaft Options

Standard keyed shaft, 0.625 inch (15,88 mm) diameter;

Optional spline shaft, 0.623/0.622 inch diameter standard SAE 9 tooth, 16/32 DP 30° involute spline.

### Outlet Port Options

Standard pressure models have SAE ports. The high pressure "H" option requires the use of outlet port option "A" (Autoclave Medium Pressure, Butech M/P or equivalent fittings), or outlet port option "B" (British Standard Pipe Parallel fittings).

### Inlet Conditions

Pumps may require pressurized inlet conditions at higher speeds. Failure to meet minimum inlet requirements will result in a slight flow reduction. Refer to the table.

### Orientation/Drive

Shaft horizontal is preferred with inlet vertically up. Vertical shaft mounting is possible, but requires connecting a line to the vertical bleed port in the pump housing. Refer to the installation drawing on page 3.

### Seal Options

Standard seals are Fluorocarbon (Viton® or Fluorel®). Options include EPR seals for use with some phosphate ester fluids, or Fluorocarbon with high pressure shaft seal.

## Minimum Inlet Pressure<sup>①</sup>

Pump Models	Operating Speed							
	1500 rpm		1800 rpm		2800 rpm		3600 rpm	
	psi	bar	psi	bar	psi	bar	psi	bar
PF501	0	0	0	0	0	0	5	0,4
PF504	0	0	0	0	0	0	5	0,4
PF507	0	0	0	0	5	0,4	10 <sup>②</sup>	0,7 <sup>②</sup>
PF510	0	0	0	0	10 <sup>②</sup>	0,7 <sup>②</sup>	15 <sup>②</sup>	1,0 <sup>②</sup>
PF511	0	0	0	0	0	0	5	0,4
PF514	0	0	0	0	0	0	5	0,4
PF517	0	0	0	0	5	0,4	10 <sup>②</sup>	0,7 <sup>②</sup>
PF520	0	0	0	0	10 <sup>②</sup>	0,7 <sup>②</sup>	15 <sup>②</sup>	1,0 <sup>②</sup>

① Values shown are based on fluid viscosity of 100 SUS (20 cSt).

② Inlet pressures higher than 10 psig (0,7 bar) require a high pressure shaft seal. Refer to "Typical Model Code" on page 6 to specify seals.

## Hydraulic Fluid Viscosity Guidelines<sup>①</sup>

Operating							
Minimum		Maximum		Start-up		Optimum	
SUS	cSt	SUS	cSt	SUS	cSt	SUS	cSt
52	8	1911	413	3706	800	98 to 324	20 to 70

① If fluid conditions fall outside of the range shown, contact the Sales department.

### Minimum Filtration Levels

Pump inlet: 150 μ nominal;  
Pressure or return line: 25 μ nominal.

Restricting flow to the pump inlet should be avoided. Minimum recommended inlet conditions must be maintained.

### Weight (Mass)

11.9 lb (5,4 kg)

### Split-Flow® Options

Refer to *Split Flow® Models* on page 4 for optional piston flow splits for this pump. Contact the Sales department for availability.

### Reduced Output Option

Pump output can be reduced by one-half by deactivating two pistons (PF511, PF514, PF517, PF520 models only). This can be an advantage in applications where available input power is limited. Refer to *Typical Model Code* on page 6.

## FLUID RECOMMENDATIONS

### Mineral Oil

A high-grade premium petroleum-based fluid should be used to assure long component and system life. The fluid should have a combination of anti-wear, demulsibility, rust protection, oxidation-resistant, and foam-resistant properties.

### Special Fluids

Some pump models may require reduced operating pressures when using low-lubricity fluids.

Because of the wide range of fluid characteristics, contact the Sales department for a review of any application using non-petroleum based fluids.

### Viscosity Specifications

Using fluid with the correct viscosity range is critical to achieving long component life.

Fluid conditions outside the "Optimum" range shown in the table may result in reduced pump output, requiring pressurized inlet conditions. For more information, contact the Sales department.

## INSTALLATION

All dimensions are shown in inches (millimeters in parentheses) and are nominal. The drawing shows dimensions common to all PF500 models. See Shaft Options on page 2 for spline shaft data.

Note that the location of the outlet port varies as shown, dependent on the type of port. Refer to *Typical Model Code* on page 6 to specify the drive shaft, outlet port and seals.

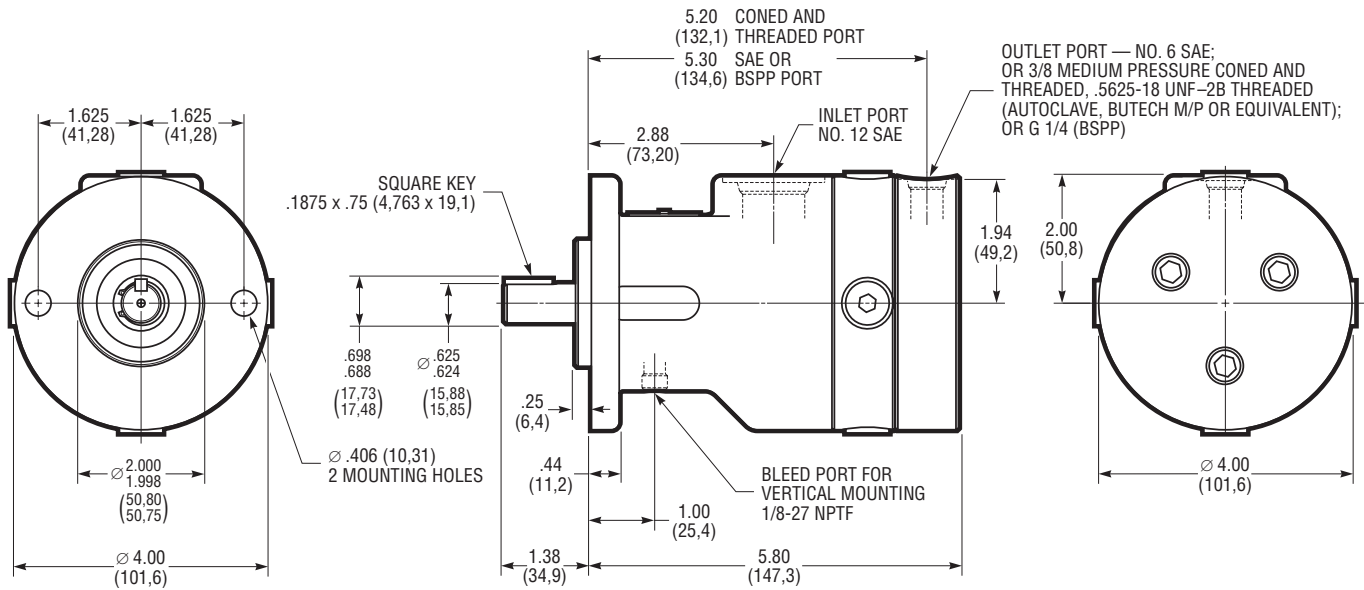

Three piston models: PF501, PF504, PF507, PF510, (PF501H, PF504H, PF507H, PF510H)

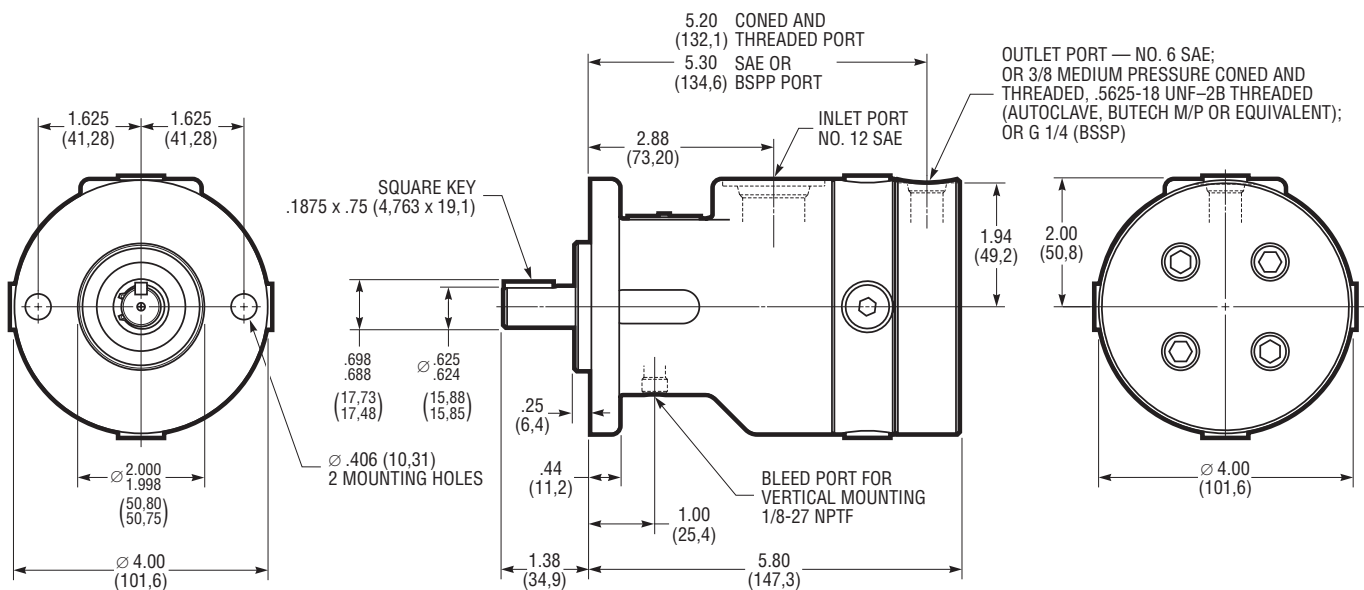

Four piston models: PF511, PF514, PF517, PF520, (PF511H, PF514H, PF517H, PF520H)

## SPLIT-FLOW® MODELS

Split-Flow® provides multiple outlets from a single pump. Models with Split-Flow® covers efficiently supply two or more flows for multiple function circuits. Multiple outlet pumps can be used for synchronized actuator movement.

Piston outputs are grouped together in the cover with various piston flow splits available depending on whether it's a four-piston pump or a three-piston pump.

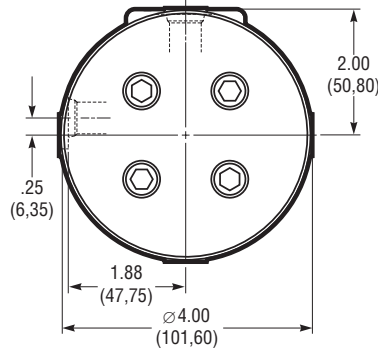

Two-pistons output + Two-pistons output

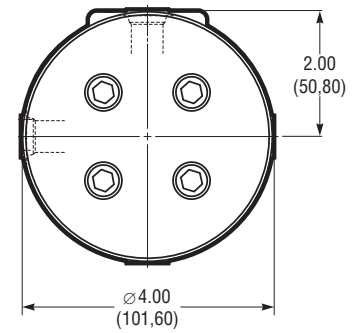

Three-pistons output + One-piston output

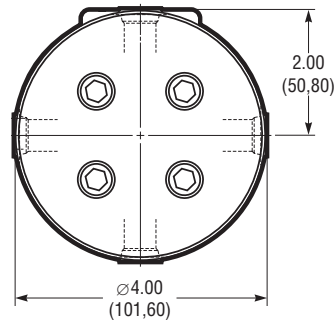
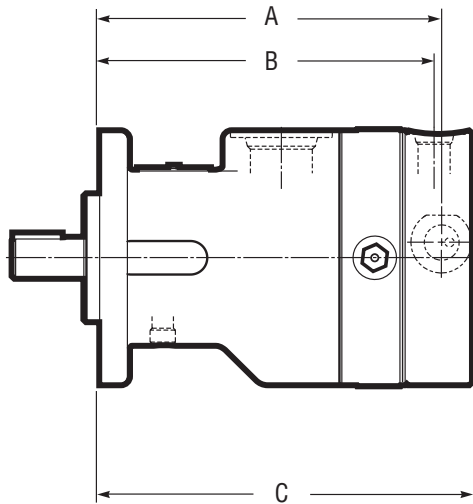

Four ports, each with one-piston output

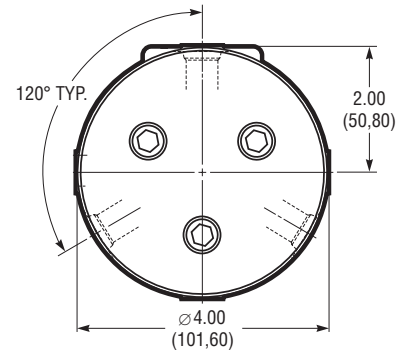

Three ports, each with one-piston output

## VARIABLE DIMENSIONS AND PORT LOCATIONS<sup>①②</sup>

DIM	2x2			3+1			4X			3X		
	SAE	MP	BSPP	SAE	MP	BSPP	SAE	MP	BSPP	SAE	MP	BSPP
A	5.43	5.55	5.43	5.30	5.20	5.30	5.30	5.20	5.30	5.30	5.20	5.30
B	5.30	5.20	5.30	5.30	5.20	5.30	5.30	5.20	5.30	5.30	5.20	5.30
C	5.93	5.93	5.93	5.80	5.80	5.80	5.80	5.80	5.80	5.80	5.80	5.80

① See "Typical Model Code" on page 6 for port size information.

② SAE – Society of Automotive Engineers.

MP – Medium Pressure, Coned and Threaded, Autoclave, Butech M/P or equivalent fitting.

BSPP – British Standard Pipe Parallel.

# TYPICAL PERFORMANCE CURVES

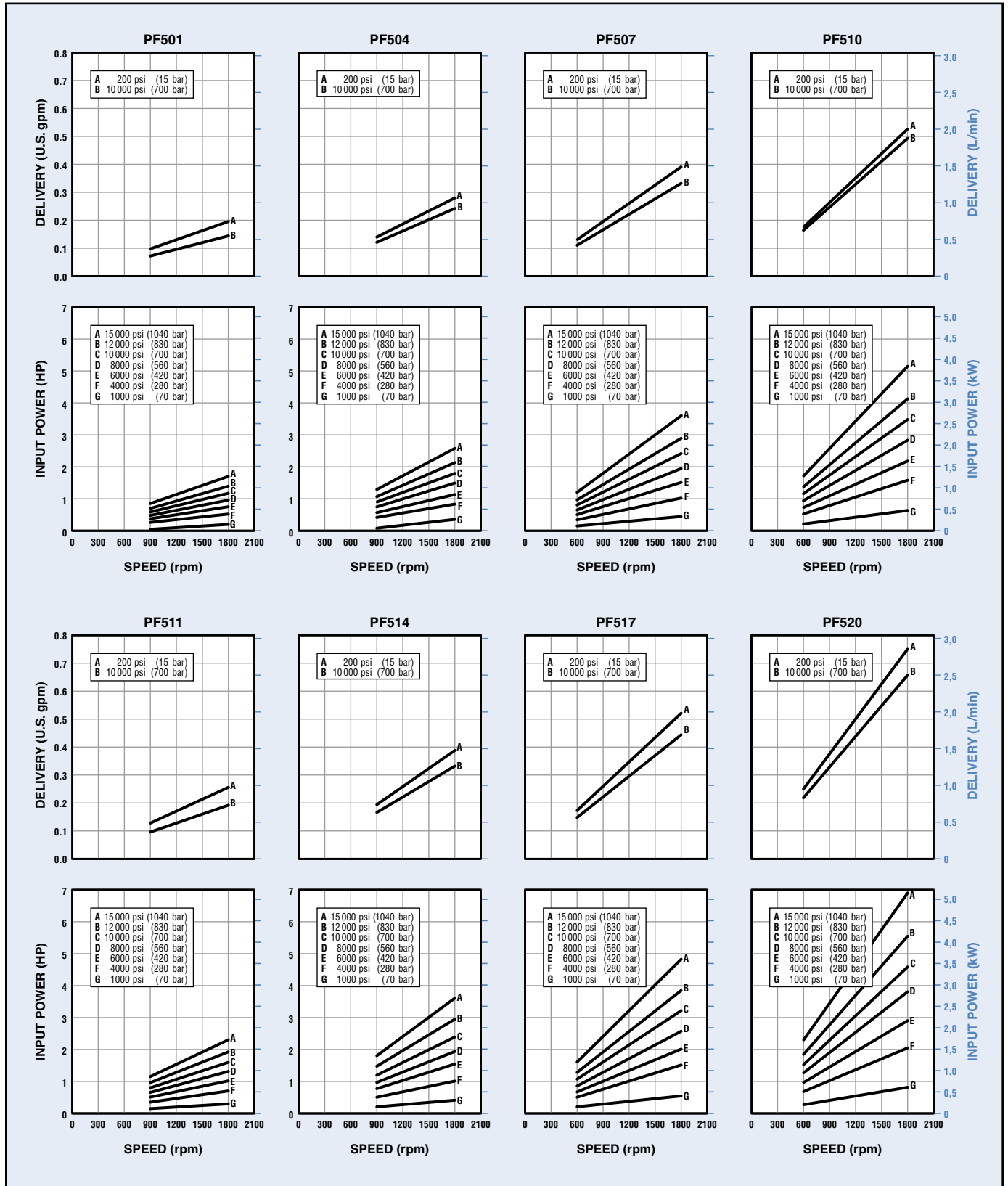

Typical performance curves are based on 100 SUS (20 cSt) mineral oil with pressurized inlet where required. Refer to the "Minimum Inlet Pressure" table on page 2. Contact the Dynex Sales department for applications requiring continuous duty operation at speeds higher or lower than shown.

# TYPICAL MODEL CODE

PF5

01

H – S XV

A

–

2 – 2

0

Pump Type	
PF5	Fixed Displacement Checkball Pump

Output Flow (At 1800 rpm, at Rated Pressure) <sup>①</sup>	
01	Standard: 0.16 gpm (0,59 L/min) "H" option: 0.15 gpm (0,55 L/min)
04	Standard: 0.25 gpm (0,95 L/min) "H" option: 0.24 gpm (0,90 L/min)
07	Standard: 0.35 gpm (1,31 L/min) "H" option: 0.34 gpm (1,26 L/min)
10	Standard: 0.51 gpm (1,93 L/min) "H" option: 0.50 gpm (1,88 L/min)
11	Standard: 0.21 gpm (0,78 L/min) "H" option: 0.19 gpm (0,73 L/min)
14	Standard: 0.33 gpm (1,26 L/min) "H" option: 0.32 gpm (1,21 L/min)
17	Standard: 0.46 gpm (1,75 L/min) "H" option: 0.45 gpm (1,68 L/min)
20	Standard: 0.68 gpm (2,58 L/min) "H" option: 0.66 gpm (2,51 L/min)

<sup>①</sup> Output flows based on typical performance at rated pressure. Refer to performance curves for flows at lower pressures.

Operating Pressure	
No Code	Standard Pressure
H	High Pressure <sup>①</sup>

<sup>①</sup> Requires "A" or "B" port option.

Drive Shaft	
No Code	Keyed, 0.625 inch (15,88 mm) diameter
S	SAE Spline, 0.625 inch (15,88 mm) <sup>①</sup>

<sup>①</sup> Contact the Sales department for availability.

Ports	
No Code	Inlet No. 12 SAE; Outlet No. 6 SAE <sup>①</sup>
A	Inlet No. 12 SAE; Outlet 3/8 Medium Pressure Coned and Threaded, 0.5625-18 UNF-2B Threaded <sup>②</sup>
B	Inlet No. 12 SAE; Outlet G 1/4 (BSPP) <sup>③</sup>

<sup>①</sup> Not recommended for operation above 8000 psi (560 bar). Contact the fitting manufacturer for the pressure rating of the fitting.  
<sup>②</sup> High pressure port uses Autoclave Medium Pressure, Butech M/P or equivalent fitting.  
<sup>③</sup> Outlet port uses British Standard Pipe Parallel fitting. Not recommended for operation above 10 000 psi (700 bar).

Cover Options (Split-Flow <sup>®</sup> )	
No Code	Full flow from single outlet
<i>Reduced Flow Models:</i>	
2	Two-pistons output + Two-inactive pistons <sup>①</sup>
<i>Split-Flow<sup>®</sup> Cover Models:</i>	
22	Two-pistons output + Two-pistons output <sup>①</sup>
31	Three-pistons output + One-piston output <sup>①②</sup>
4X	Four ports, each with one-piston output <sup>①</sup>
3X	Three ports, each with one-piston output <sup>③</sup>

<sup>①</sup> Available on models PF511, PF514, PF517, PF520 only.  
<sup>②</sup> Port for outlet flow designated by first digit is located at the 12 o'clock position (for code "31", three-piston output flow exits the 12 o'clock port).  
<sup>③</sup> Available on models PF501, PF504, PF507, PF510 only.

Seals	
No Code	Fluorocarbon (Viton <sup>®</sup> or Fluorel <sup>®</sup> ) Seals with Buna-N (Nitrile) Shaft Seal
XE	All EPR with High Pressure Shaft Seal <sup>①</sup>
XV	All Fluorocarbon (Viton <sup>®</sup> or Fluorel <sup>®</sup> ) with High Pressure Shaft Seal

<sup>①</sup> Not available with high pressure "H" option. Contact the Sales department for recommended operating conditions.

Design Number

Modification Number

Specifications shown were in effect when printed. Since errors or omissions are possible, contact your sales representative or the Sales department for the most current specifications before ordering. Dynex reserves the right to discontinue products or change designs at any time without incurring any obligation.

[www.dynexhydraulics.com](http://www.dynexhydraulics.com)

### USA Headquarters

770 Capitol Drive  
 Pewaukee, WI 53072  
 Tel: +1 (262) 691-2222  
 FAX: +1 (262) 691-0312  
 sales@dynexhydraulics.com

### Power Units & Systems

54 Nickerson Road  
 Ashland, MA 01721  
 Tel: +1 (508) 881-5110  
 ashland@dynexhydraulics.com

### European Sales

Unit C5 Steel Close, Little End Road,  
 Eaton Socon, St Neots,  
 Cambs. PE19 8TT United Kingdom  
 Tel: +44 (0) 1480 213980 FAX: +44 (0) 1480 405662  
 sales@dynexhydraulics.co.uk





## FLUID RECOMMENDATIONS (All Checkball Pumps)

### Mineral Oil

A high-grade premium petroleum-based fluid should be used to assure long component and system life. The fluid should have a combination of anti-wear, demulsibility, rust protection, oxidation-resistant and foam-resistant properties.

### Special Fluids

Various pump models are available for use with water-based fluids, diesel calibration fluids, phosphate ester fluids, machining coolant, brake fluid, various military fluids and other special fluids.

PF1300 & PF4300 Series pumps are compatible with a variety of water-based fluids. Refer to specific product documentation for specifications for these models, which are specifically rated for use with low-lubricity fluids.

Some pump models may require reduced operating pressures when using low-lubricity fluids.

Refer to separate bulletin: [Water-Based Fluid and Port Specifications](#) for use with water-based fluids.

Because of the wide range of fluid characteristics, contact the Sales department for a review of any application using non-petroleum based fluids.

### Viscosity Specifications

Using fluid with the correct viscosity range is critical to achieving long component life.

Fluid conditions outside the "Optimum" range shown in the table may result in reduced pump output, requiring pressurized inlet conditions. For more information, contact the Sales department.

## Hydraulic Fluid Viscosity<sup>①</sup>

Pump Models	Operating				Start-up		Optimum	
	Minimum		Maximum		SUS	cSt	SUS	cSt
	SUS	cSt	SUS	cSt				
<i>Fixed Displacement Pumps:</i>								
PF500-20	52	8	1911	413	3706	800	98 to 324	20 to 70
PF1000-10	59	10	1911	413	3706	800	98 to 324	20 to 70
PF1300-11 <sup>②</sup>	–	–	–	–	–	–	–	–
PF2000-10	59	10	1911	413	1911	413	98 to 324	20 to 70
PF2000 <sup>③</sup>	34	2,3	1911	413	1911	413	98 to 324	20 to 70
PF3000-10	59	10	1911	413	3706	800	98 to 342	20 to 70
PF4000-30	34	2,3	1911	413	1911	413	98 to 324	20 to 70
PF4200-10	34	2,3	1911	413	1911	413	98 to 324	20 to 70
PF4300-22 <sup>②</sup>	–	–	–	–	–	–	–	–
PF6000	34	2,3	1911	413	1911	413	98 to 324	20 to 70
<i>Mechanical Variable Delivery Pumps:</i>								
PV4000-11	34	2,3	1911	413	1911	413	98 to 324	20 to 70
PV6000	34	2,3	1911	413	1911	413	98 to 324	20 to 70
<i>Hydraulic Variable Delivery Pumps:</i>								
PV6000	34	2,3	1911	413	1911	413	98 to 324	20 to 70

① Fluid conditions outside the "Optimum" range may result in reduced output, requiring pressurized inlet conditions. Contact the Sales department.

② Refer to separate bulletin "Water-Based Fluid and Port Specifications" for use with water-based fluids.

③ Models with special mounting.

## MINIMUM FILTRATION LEVELS

Pump inlet: 150 μ nominal;

Pressure or return line: 25 μ nominal.

While finer filtration levels than these are desirable and will result in longer component life, restricting flow to the pump inlet should be avoided. Minimum recommended inlet conditions must be maintained.

If a system component fails resulting in fluid contamination, it is important to drain and clean the reservoir, all lines, filter screens and all components. Refill with new fluid.

## INSTALLATION AND OPERATION

Refer to [Checkball Pumps Service, Installation and Operating Instructions](#) for general installation and operating recommendations.

That brochure includes information on mounting, shaft loading, sizing inlet pipe and hose, air bleed procedures and initial start-up. Guidelines for maintenance, repair and trouble-shooting are also included.

## OUTLET PORT CONFIGURATIONS

Dynex pumps are available with outlet ports suitable for use at various pressure ranges. Refer to the appropriate *Specification Table* or *Typical Model Code* to specify the required port.

Contact the fitting manufacturer to ensure the selected fittings are rated for the maximum pump operating pressure.

### SAE Straight Thread Ports

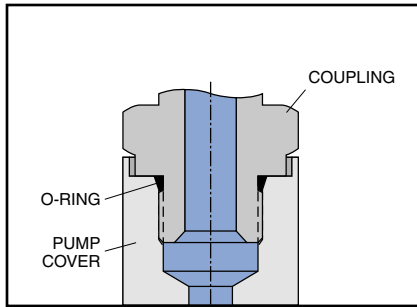

*Typical SAE Straight Thread port connection*

The Straight Thread connection (SAE J1926/1) is sometimes referred to as an SAE O-ring Boss, or ORB. The port consists of a machined spotface surface, a tapered seal cavity and a straight thread port.

The fitting forms a seal by compressing the o-ring in the seal cavity with the underside of the flanged wrench flat. Some adjustable fittings, such as elbows and tees, use a locknut with a captive backup washer for compression.

SAE Straight Thread ports are not recommended for operation above 8000 psi (560 bar). Also, the maximum pressure of pumps with No. 12 SAE outlet ports may be limited by the pressure rating of the available fitting. Contact the fitting manufacturer for ratings.

### Coned and Threaded Ports

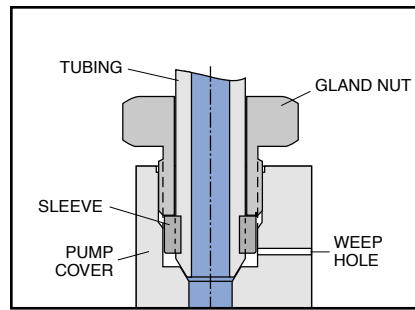

*Typical Coned and Threaded port connection*

High-pressure pumps are available with coned and threaded outlet ports, which use Autoclave Medium Pressure, Butech M/P, or equivalent fittings.

These fittings provide a metal-to-metal seal with an interference fit, not requiring an o-ring. The gland nut holds the sleeve and tubing against the cone surface.

A weep hole, visible on the outside of the pump cover, acts as an indicator of any abnormal leakage caused by system conditions (i.e., excessive pressure).

### British Standard Pipe Parallel Ports

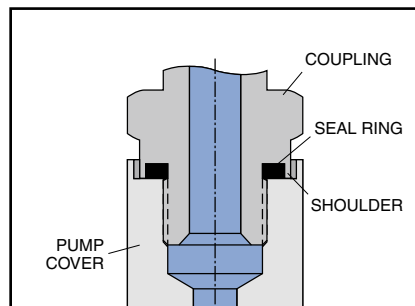

*Typical British Standard Pipe (Parallel) port connection*

High-pressure pumps are available with flat face ports with British Standard Pipe Parallel (BSPP) threads (BS 2779 or ISO 228), ideal for use on some European applications.

The fitting forms a seal by compressing a flat elastomer ring on a machined spotface surface. There are several sealing methods for these ports.

The recommended fitting has a recessed seal cavity formed by a shoulder on the underside of the flanged wrench flat (Voss "Peflex", Form B Shoulder Seal; or Parker Type E, "EOlastic" Seal; or equivalent).

BSPP ports are not recommended for operation above 10 000 psi (700 bar). Contact the fitting manufacturer to ensure the selected fittings are rated for the maximum pump operating pressure.

### SAE 4-Bolt Flange Ports

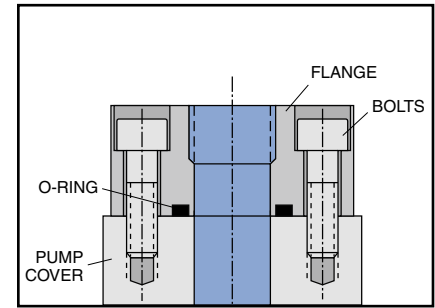

*Typical SAE 4-Bolt Flange port connection*

Flange connections are often used for higher flows requiring larger diameter tubing. The port consists of an unthreaded port with four bolt holes in a rectangular pattern on a machined face around the port (SAE J518).

A typical fitting consists of a flanged block with a welded tube and a captive flange with bolt holes. A seal is formed by an o-ring in the groove on the underside mounting surface of the flange head. As the flange bolts are alternately tightened, the o-ring is compressed between the flange head and the machined face on the pump.

To make mounting easier in tight spaces a two-piece split-flange is often used.